

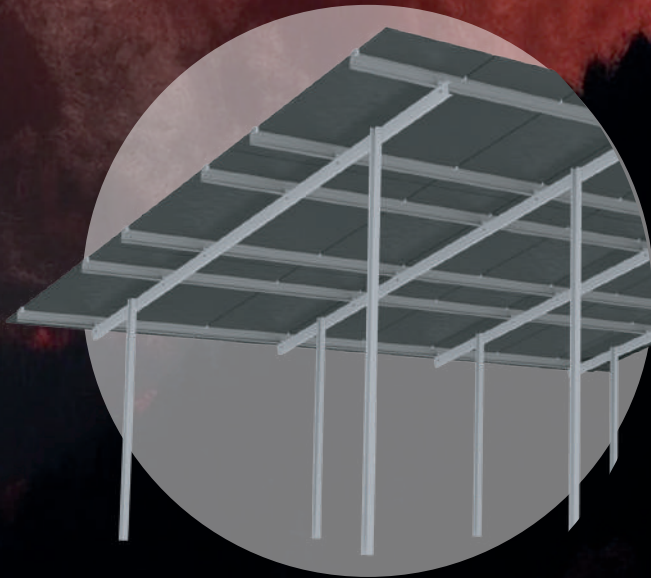

Solar energy needs strong support
hema-rack offers support - competent & results-oriented



Mounting instructions
Ground-Mounted-System





Contents

1. Scope of delivery.....	4
2. Recommended Tools:.....	5
2.1 Overview Tools.....	5
2.2 Tightening torque Screws V2A	6
3. Safety of work.....	7
4. Prerequisites.....	8
4.1 Operator obligations.....	8
4.2 Staff obligations.....	8
4.3 Training of staff.....	8
4.4 Rack tolerances.....	9
4.5 Ground slope.....	9
5. Transport, loading and unloading.....	10
5.1 Delivery of components.....	10
5.2 Delivery preparations.....	10
5.3 Scope of delivery control.....	11
5.4 Storing components.....	11
6. Installation of foundations.....	12
6.1 Reviewing GPS-points.....	12
6.2 Foundation pile-driving.....	12
6.3 Reviewing the alignment	14
6.4 Zinc dust priming-application.....	14

Contents

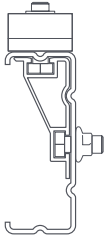
6.5 Rafter and purlin installation.....	14
6.6 Install rafter assembly.....	15
6.7 Hang in the purlin profile.....	15
6.8 Fix the purlin profile	16
6.9 Apply zinc dust primer.....	16
6.10 Install purlin truss.....	16
6.11 Attach the Vau/Snabb adapter	17
6.12 Module installation.....	18
6.13 Attach Modul	19
7. Dismantling and disposal.....	20
7.1 Dismantling.....	20
7.2 Disposal.....	22
8. Maintenance.....	21
9. Warranty and liability.....	21

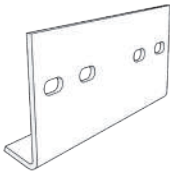
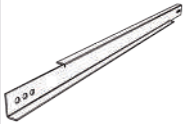
1. Scope of Delivery

					
Type	Pile-driven foundations	Girder assemblies 2.0	Purlins 2.0	Purlins connectors 2.0	Braces
ArtNo	2131-01-00001-00000	2131-09-00000-00000	2131-01-00013-00000	2111-03-00000-00250	2111-03-00001-00250
					
Type	Standard parts				
ArtNo					



NOTE: Included in delivery are EITHER
Vau middle clamp set + Vau end clamp set (Set 1)
OR Snabb adapter set + middle clamp set + end clamp set (Set 2)

Set 1

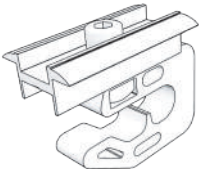
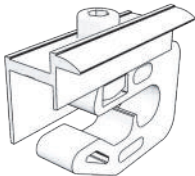
				
Type	Vau middle clamp Set	Vau end clamp Set		
ArtNo	2336-09-00009-00000	2336-09-00008-00000		

Set 2

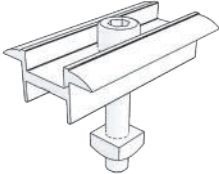
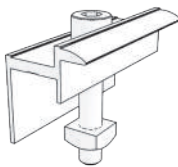
				
Type	Snabb-Adapter Set	Middle clamp Set	End clamp Set	
ArtNo	2336-09-00007-00065	5336-09-00001-00000	5336-09-00003-00000	

hema-rack Typ II

2. Recommended Tools

2.1 Overview of tools

For the installation you will need a pile-driver with a suitable impact piece and a loader for the construction site logistics (approx. 1.5 t lifting capacity).

You will also need the following tools:

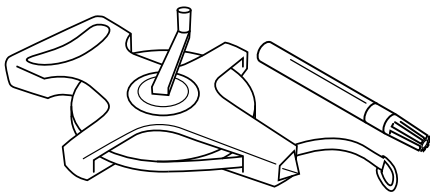

Tape measure and marker

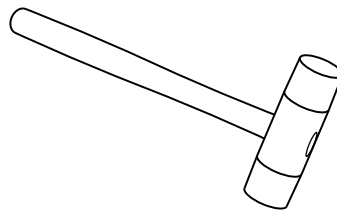

Nylon hammer

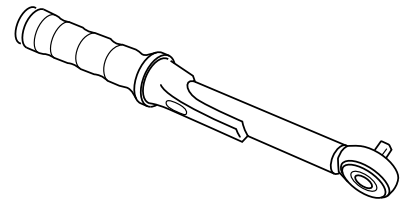

Torque wrench

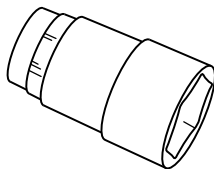

Socket wrench with
hexagon socket(nut) size 13
hexagon socket(nut) size 17
hexagon socket(nut) size 19

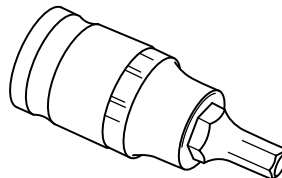

Socket wrench with
hexagon head (Inbus) AF 6

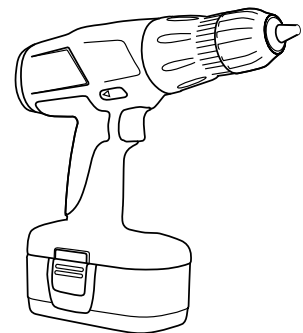

Cordless screwdriver

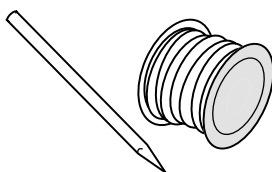

Plumb-line with marking-
nails and wooden pegs

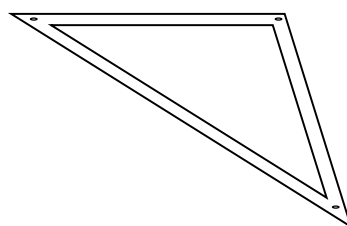

Protractor

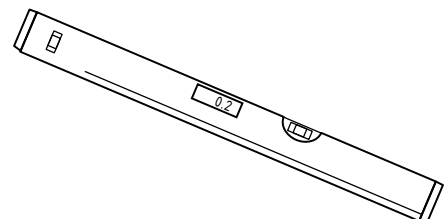

Water level with
digital angle display

hema-rack Typ II

2.2 Tightening torque screws V2A



Screw threads	Strength class 50 (e.g. turned parts)		Strength class 70 (Standard A2-70, A4-70)		Strength class 80 (e.g. A4-80)	
	Preload force in N	Tightening torque in Nm	Preload force in N	Tightening torque in Nm	Preload force in N	Tightening torque in Nm
M5	M5	1,7	3.000	3,5	4.750	4,7
M6	M6	3	6.200	6	6.700	8,0
M8	M8	7,1	12.200	16	13.700	22
M10	M10	14	16.300	32	22.000	43
M12	M12	24	24.200	56	32.000	75
M16	M16	59	45.000	135	60.000	180
M20	M20	114	71.000	280	95.000	370
M24	M24	198	105.000	455	140.000	605
M30	M30	393	191.000	1.050	255.000	1.400

hema-rack Typ II

3. Occupational safety

You must always wear a safety jacket



You must always wear safety shoes



When working in areas in which a high level of noise is generated, you must wear ear protection



You must wear a **helmet** wherever there is a risk of falling objects, or working in areas in which you might hit your head



Wear **protective gloves** when working with parts with sharp edges



Wear **respiratory protection** when undertaking any activities which generate dust or emit fumes



Wear safety goggles when grinding and cutting, as well as during activities where flying parts/liquids could endanger your eyes.



hema-rack Typ II

4. Prerequisites

4.1 Operator obligations

The operator undertakes to only allow persons to work on and in the vicinity of the system who:

- have read and understood all parts of the installation instructions relevant to the respective activity
- are familiar with the regulations on occupational safety, accident prevention, and environmental protection
- have been instructed in the safe handling of the system.

Before starting assembly, the operator shall organize

- a supervising person
- inspection of the construction site with the aid of utility plans,
- clear marking or cordoning off of all types of underground cables and non-load-bearing earth cables.

4.2 Staff obligations

- Only persons who can be expected to perform their work reliably are permitted to work as staff. - Persons whose responsiveness is impaired, e.g. by drugs, alcohol, or medication are not permitted to work.
- Every person involved in the assembly of hema -rack Type II must have read and understood these assembly instructions, especially the instructions on occupational safety, as well as all relevant chapters relating to the respective activity.
- These assembly instructions should be kept accessible to all employees at the assembly site.
- Only appropriately trained persons may carry out the activities described in the instructions.
- Trainee personnel may only participate in the assembly under the supervision of experienced employees.

4.3 Staff training

Only qualified personnel from the fields of transport, assembly, disassembly, and disposal with the following qualifications are suitable for installing the system:

- The personnel are capable of carrying out the work assigned to them and independently recognizing potential hazards and avoiding them based on their professional experience and training.
- The personnel have the necessary knowledge of the regulations applicable at the respective construction site, accident prevention and environmental protection guidelines, as well as the regulations for loading and unloading.
- The specialist personnel have the driving licenses required at the respective construction site to drive construction site vehicles and construction machinery.

hema-rack Typ II

4.4 Rack tolerances

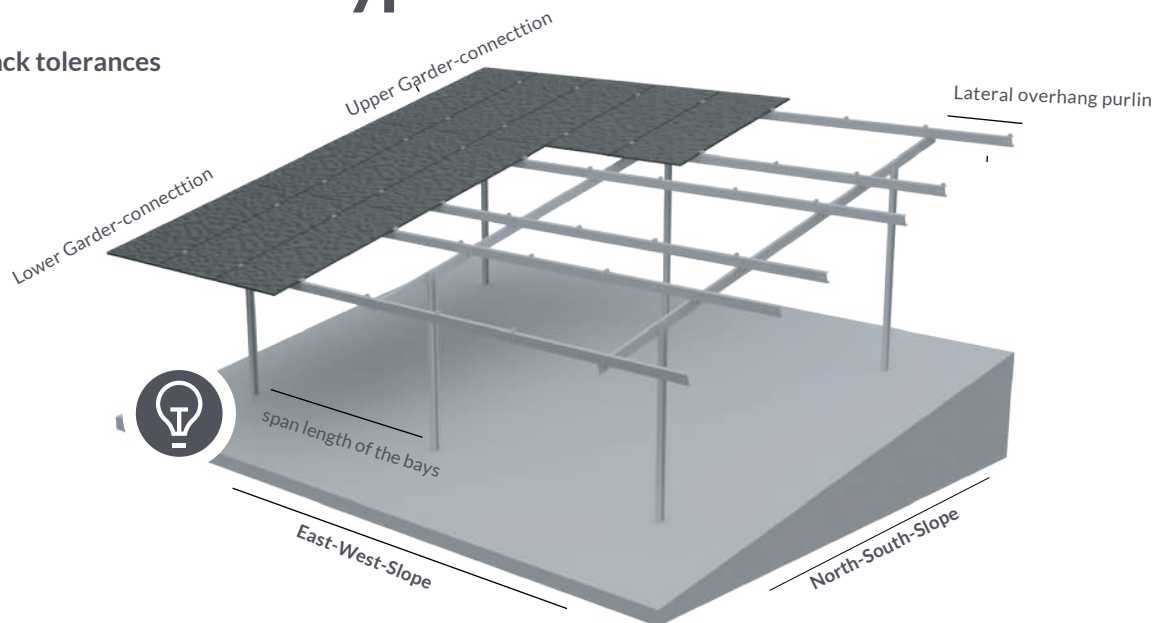

hema-rack Type II is designed to suit the wind and snow conditions at the respective location. The individual components are designed according to their respective load-bearing capacity in order to ensure cost-effectiveness. This means that they must be assembled with a high degree of precision; deviations from the assembly instructions may result in static overloads. The manufacturer cannot accept any liability for this. Compliance with the tolerances is essential for the stability of the rack!

Support width of the	± 150 mm	Lower truss connection	± 100 mm
Lateral projection	± 100 mm	Upper truss connection	± 100 mm

4.5 Terrain slope

Please note the maximum permissible terrain slopes during the planning stage (see figure above)! The following guidelines must be considered in relation to the slope characteristics, soil composition, and rock type.

Maximal terrain slope East-West: 5°	Maximal terrain slope North-South: 30°
--	---



On steep slopes, pile driving foundations are only advisable in dry, ice-free weather conditions to ensure smooth pile driving.

hema-rack Typ II

5. Transport, loading and unloading



- ▀ Always wear protective equipment in accordance with Chapter 3, Occupational Safety.
- ▀ Observe additional internal safety regulations.
- ▀ It is essential to monitor the entire unloading process.
- ▀ Never stand under raised loads.
- ▀ Ensure that no unauthorized persons are in the danger zone.
- ▀ Observe all country-specific regulations and standards of the receiving country.
- ▀ any unloading guidelines for delivery by sea container.



The following accompanying documents must be checked upon delivery:

- ▀ Delivery notes
- ▀ Packing lists

5.1 Delivery of components

The components for hema -rackType II are delivered using a suitable vehicle, e.g., by truck.

5.2 Preparation for delivery

- ▀ Ensure that all access roads and unloading areas are accessible to trucks (up to 40 tons) and can be used by forklifts and lifting equipment.
- ▀ Organize suitable forklifts and lifting equipment for the time of delivery.
- ▀ Provide forklifts and lifting equipment with different or adjustable fork spacing.
- ▀ Ensure that components, pallets, and long goods can be unloaded properly.

hema-rack Typ II

5.3 Checking the scope of delivery

We recommend that you also consider the following points when receiving the goods:

- ▀ General condition of the goods and packaging
- ▀ Visual inspection of the delivered goods for damage
- ▀ Comparison with the delivery order



Any claims for defects must be reported immediately in accordance with § 377 HGB (German Commercial Code).

If possible, contact your designated contact person at the supplier or at hema-rack GmbH within 24 hours.

Please note that we cannot accept any claims for damage to goods that are not reported to us within 24 hours with hema rack GmbH.

Contact hema rack GmbH 43 5373 212 60

5.4 Storage of component

The components include fragile and sensitive parts, some of which are packed in cardboard boxes.

- ▀ Only unload the components on firm, stable ground.
- ▀ Protect all components from rain, snow, moisture, and other weather conditions.



In addition to these installation instructions, the following documents are also required for the installation:

- ▀ Pile-driving plan
- ▀ Overview drawing
- ▀ Parts lists
- ▀ Delivery note
- ▀ PV-module manufacturer's installation instructions

hema-rack Typ II

6. Assembly

6.1 Verification of GPS-Points

Checking the GPS points is particularly important in very uneven terrain. In such cases, there may be a large offset of the pile foundations in the north-south direction. However, it makes module installation considerably more difficult if the trusses (girders) are not parallel to each other.

Therefore, before starting the pile driving work, check the GPS points with an angle and string, as shown below:



6.1 Drive the foundation pile in accordance with the specified tolerances

The exact positions for the piles can be found in the corresponding pile-driving plan.

Ensure correct orientation of the piles:
The open side must face uniformly eastward (to the right) when standing in front of the table.

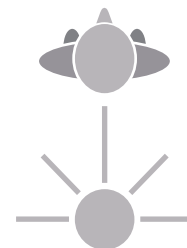

hema-rack Typ II



Pile-driving tolerances

Tilt
North-South: $\pm 3^\circ$

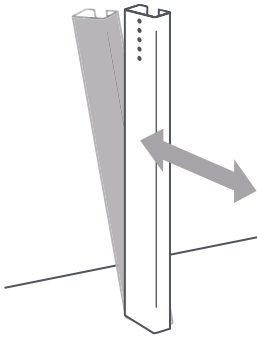

Tilt
East-West: $\pm 3^\circ$

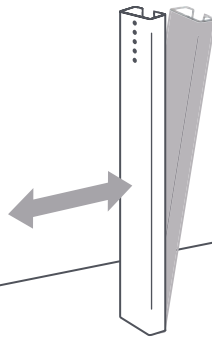

Embedment depths
 ± 100 mm

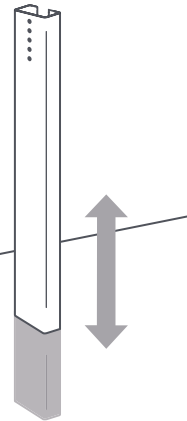

Rotation $\pm 5^\circ$

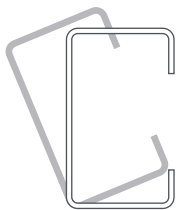

Height difference
within a row: ± 30 mm

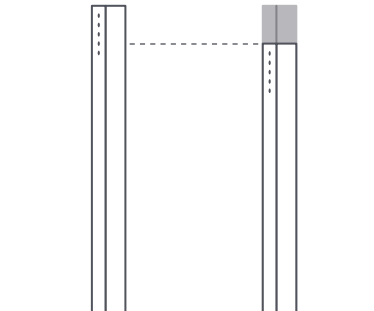

hema-rack Typ II

6.3 Verification of the alignment

Check the alignment of the individual piles in relation to each other and check the compliance to the tolerances (see 6.2)



6.4 Apply Zinc dust primer

Coat the rammed pile at the upper end inside and outside with approx. 30mm of zinc dust primer (primer needs to have 90% zinc)

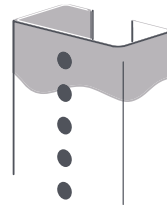

6.5 Girder (binder) and purlin installation



- ▀ Wear suitable protective equipment when installing girders and purlins!
- ▀ Never stand under suspended loads and secure objects to prevent them from falling over and tools from falling down!
- ▀ Secure parts to prevent them from slipping!
- ▀ Use suitable aids for heavy loads and ask colleagues for help!
- ▀ Keep the work area tidy to prevent falls!



Tighten screw connections only on the screw head side; hold the nut in place while doing so.

hema-rack Typ II

6.6 Installation of the girder assembly

Screw the connector with hexagonal screw M12 x 25 DIN 933 and flange nut M12 DIN 6923 to the pile foundation.

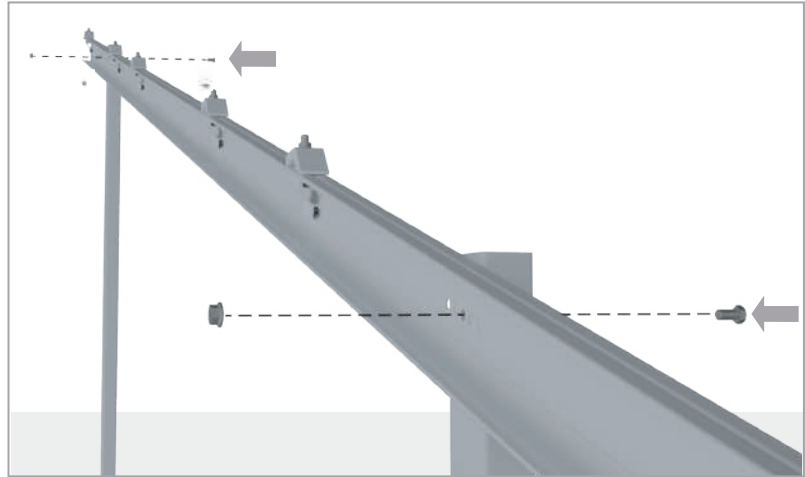

Please note that the purlin profile must be mounted at a 90-degree angle to the truss so that the modules are properly supported.
If the purlins are mounted imprecisely, the modules could slip down under load.

6.7 Hook the purlin profiles into the pre-assembled clamps on the girder assembly

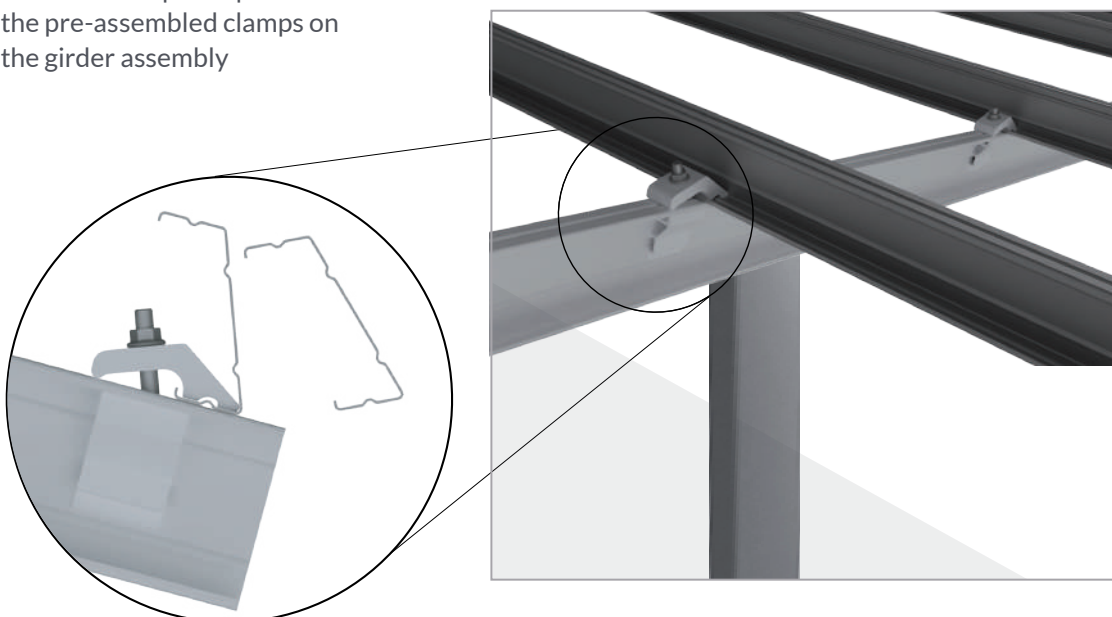

hema-rack Typ II

6.8 6.8 Screw down and tighten purlin profile

Tighten the screws on the clamps



6.9 OPTIONAL:

Coat the cut edges of the girder and purlin profiles with zinc dust primer

The primer prevents aesthetic impairment of the edges due to flash rust.

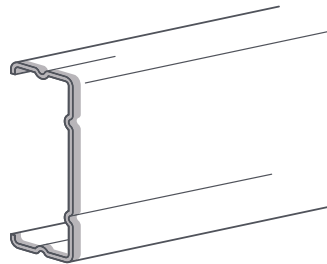

6.10 OPTIONAL:

Mount the purlin connectors

Attach purlin connectors with 4 hexagon head screws M12 x 25 DIN 933 and flange nuts M12 DIN 6923 to the purlin profiles.

For installation use the pre-drilled holes provided on the purlin profiles!

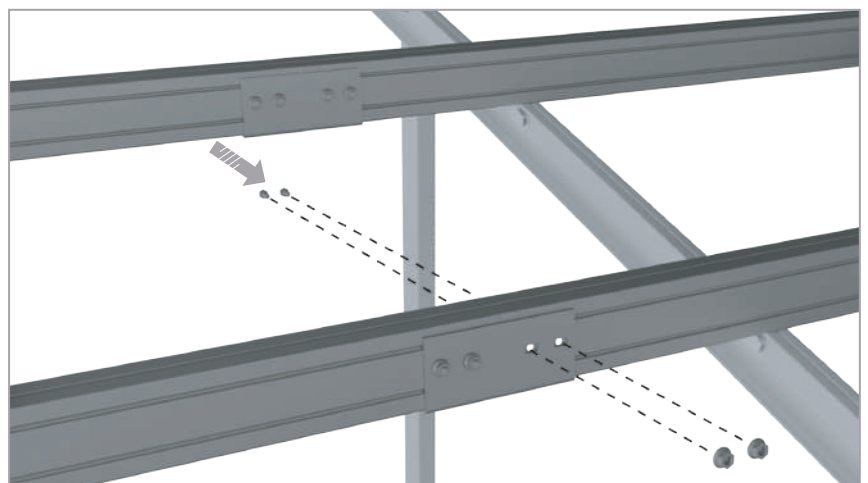

hema-rack Typ II

6.11 Installation of module clamps

6.11.1 Vau-Module-Clamp-Set (used in vertical module orientation)

Hook the Vau-Middle- and Vau-End-Clamp-Sets to the purlin profile

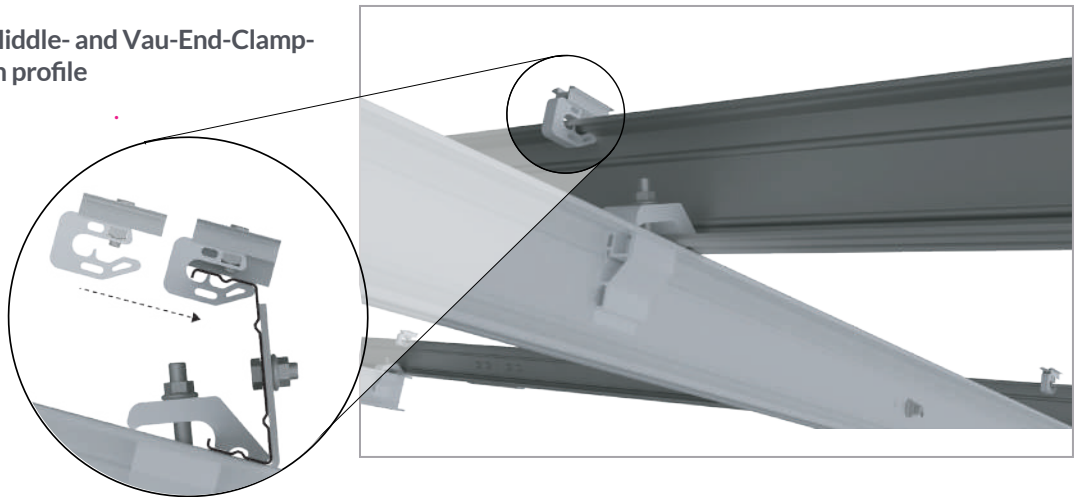

6.11.2 Snabb-Adapter-Set (used in horizontal module orientation)

Hook the Snabb-Adapters into the purlin section

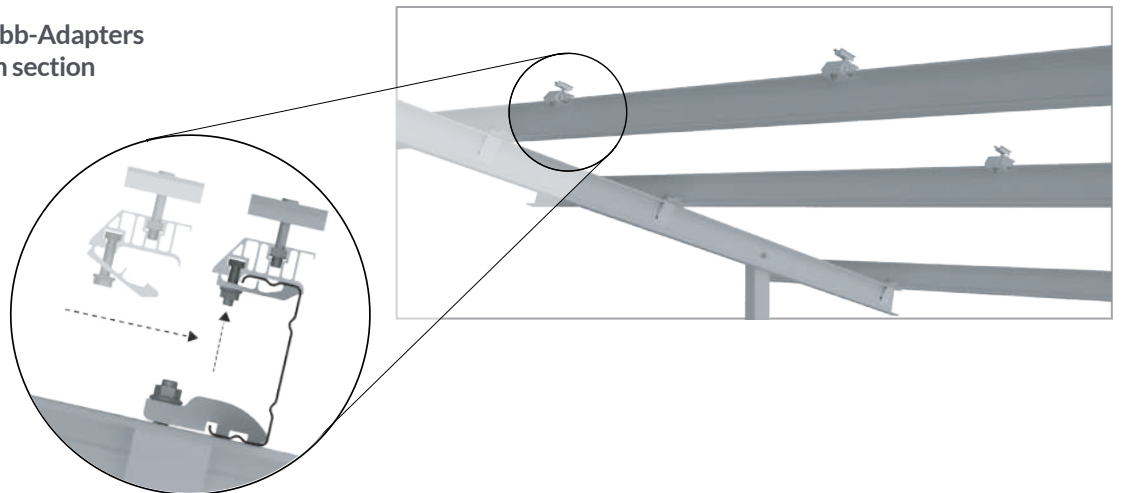

Please refer to the overview drawing for the exact position of the Vau- or Snabb-adapter set. Please also refer to the module manufacturers specification in the installation manual of the modules. Please pay particular attention to the specified torque for the module clamping. These torques have priority over the torques listed for the mounting structure and clamps.

hema-rack Typ II

6.12 Installation of modules



The solar modules of the system are third-party components that are not included in the scope of delivery of the hema-rack Type II! hema-rack GmbH therefore expressly refers to the safety and installation instructions of the respective module manufacturer (in addition to the specifications in these installation instructions).

The following points must be observed in all cases:

- ▀ PV modules are electrical devices that must be handled with care.
- ▀ The modules must not be weighted down.
- ▀ They must not be contaminated or scratched.
- ▀ Avoid impacts, shocks, or vibrations of any kind.
- ▀ Do not pull on the cables. The cables should not be bent sharply.



Module clamping -gap dimensions

During project planning, the module clamping can be specified in a vertical, horizontal, or combined design.

The module clamping can be specified in a vertical, horizontal, or combined design.

The standard value for the gap between the modules on the side without clamps is 10 mm.

5 mm

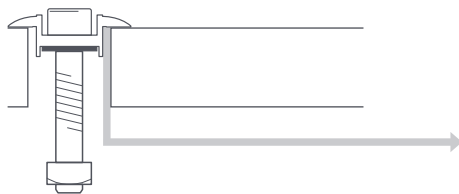
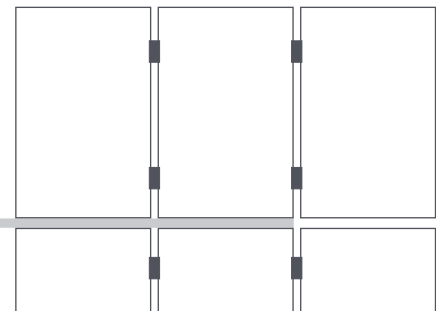

The gap size, i.e., the distance between the module and the module clamp, is at least 0.5 mm.

hema-rack Typ II

6.13 Push the modules to the module clamps and tighten the allen screw

6.13.1 Vau-Middle and Vau-End-Clamps:
Slide the module into the clamp and tighten the hexagon allen-head-screws

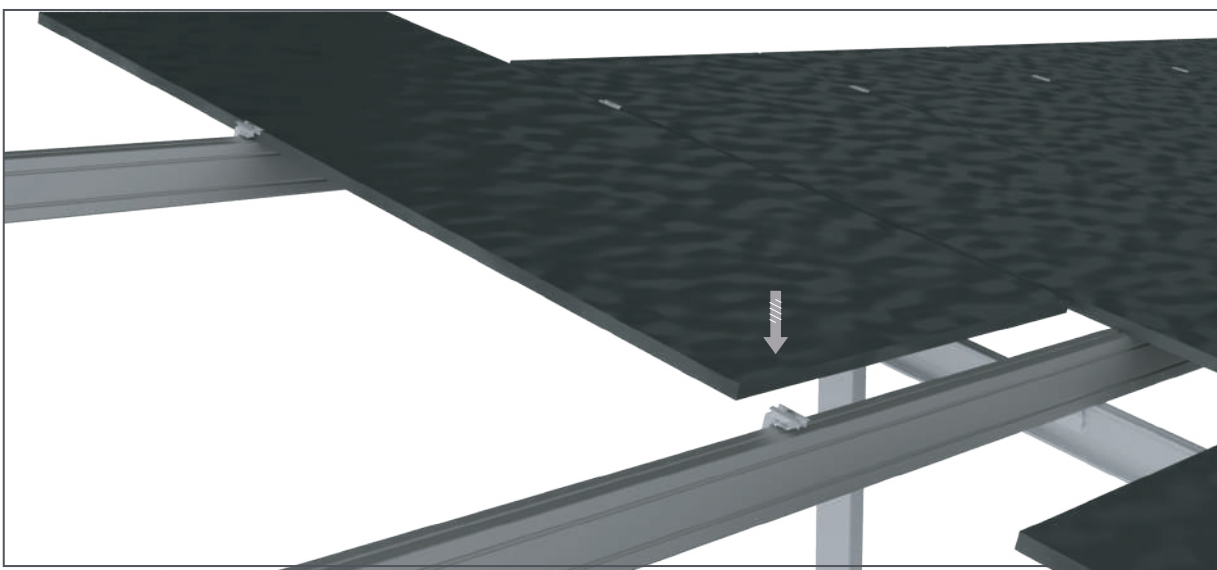

6.13.2 Snabb Adapter:

Slide the module into the clamp and tighten the hexagon allen-head-screws

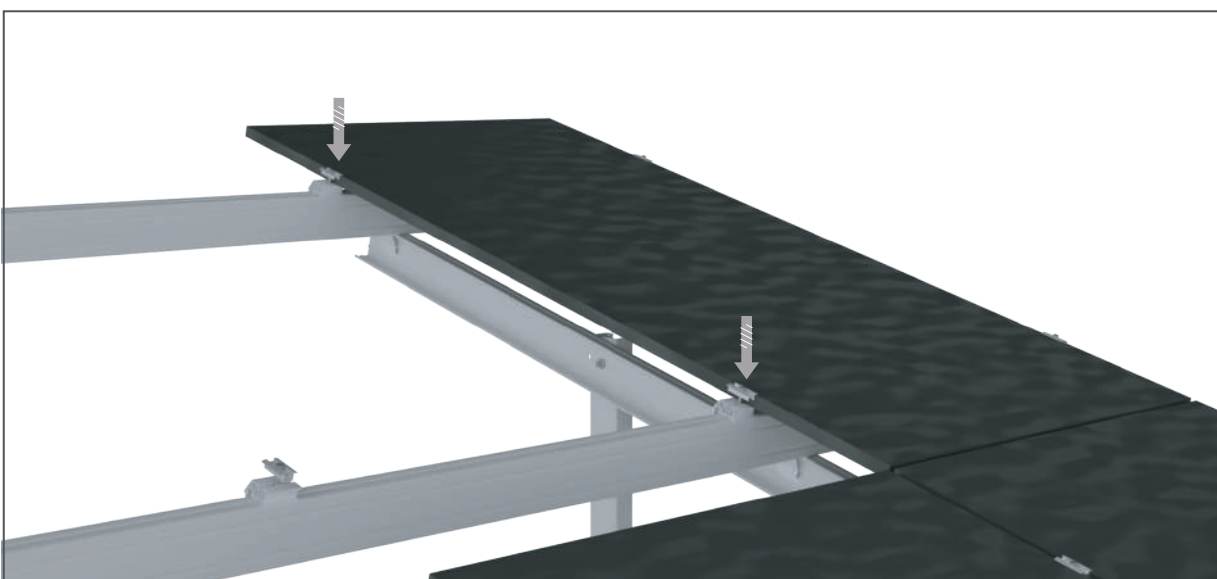

hema-rack Typ II

7. Dismantling and disposal



The system operates at high voltage!

- ▀ Observe all instructions and safety information provided by the manufacturer of the modules or electronic components before decommissioning the system.
- ▀ Only allow qualified electricians to disconnect the system from the on-site power supply.
- ▀ Have the qualified electrician confirm that the system has been properly decommissioned before you begin dismantling it.



- ▀ Always wear protective equipment and clothing in accordance with Chapter 3, Occupational Safety
- ▀ Never stand or walk under raised loads.
- ▀ Ensure that no unauthorized persons enter or are in the danger zone.

7.1 Disassembly

The system can be dismantled into individual transportable parts by a trained specialist. The dismantling work must be carried out in exactly the reverse order to the assembly.

7.2 Disposal

- ▀ All materials used in the plant are recyclable and must therefore be sorted and separated: steel, synthetic materials, electro scrap, aluminium, stainless-steel, copper etc.
- ▀ You are obligated to dispose of the components in accordance with local and legal regulations

hema-rack Typ II

8. Maintenance



Proper maintenance of the system includes the following activities:

- ▀ Checking screw connections
- ▀ Checking the system for corrosion
- ▀ Cleaning of modules
- ▀ Maintaining access roads and access routes

- ▀ Inspect the system for damage after unusual weather events such as storms, hail, heavy snowfall, or heavy rain.
- ▀ If damage to the frame or changes to the ground occur, it is essential to repair the system. If the system is not repaired, it may become unstable and fall over.

9. Warranty and liability

The customer is solely responsible for the proper installation of the hema rack Type II.

Exclusions:

Warranty, guarantee, and liability claims against hema rack GmbH for personal injury and property damage are excluded if they are attributable to one or more of the following causes:

- ▀ Failure to follow the installation instructions
- ▀ Failure to follow the maintenance instructions
- ▀ Improper use of the hema-rack Type II
- ▀ Improper assembly, maintenance, or repair
- ▀ Operation with defective or unsuitable components that have not been approved by the manufacturer
- ▀ Unauthorized structural modifications or manipulation of the hema-rack Type II or its components
- ▀ Neglect of the specified maintenance or inspection requirements

Damage and consequential damage attributable to one or more of the above causes shall be borne exclusively by the operator.

The warranty provided by hema-rack GmbH applies exclusively to the hema-rack Type II rack. This warranty does not extend to other components of the photovoltaic system, such as modules, cables and connectors, inverters, or electrical switchgear.

Property damage to items not included in the scope of delivery is excluded from any liability.